



Union Special
INDUSTRIAL SEWING EQUIPMENT

STYLES

**ADJUSTING INSTRUCTIONS AND
ILLUSTRATED PARTS LIST**

**39500A
39500B
39500P
39500AF**

**CATALOG
NO. 103S**

STREAMLINED HIGH SPEED OVERSEAMERS

**SECOND
EDITION**

SECOND EDITION
© 1957

PRINTED 1996 IN USA

INFORMATION SUBJECT TO CHANGE WITHOUT NOTICE

© UNION SPECIAL CORPORATION ALL RIGHTS RESERVED IN ALL COUNTRIES.

FOREWORD

The Class 39500 machine is Union Special's latest overedger. New streamlined styling, automatic lubrication, and light running high speed performance are characteristics of these machines. All parts are made by precision methods insuring complete interchangeability.

It is our constant aim to furnish carefully prepared information that will enable the customer to secure all possible advantages from the use of Union Specials. The following pages contain valuable operating and adjusting data, and illustrate and describe the parts for Styles in Class 39500.

Union Special representatives will be found in all manufacturing centers, anxious to cooperate with you to plan and estimate requirements.

Union Special MACHINE COMPANY

Engineering Department

IDENTIFICATION OF MACHINES

Each Union Special carries a Style number which is stamped in the name plate on the machine. Style numbers are classified as standard and special. Standard Style numbers have one or more letters suffixed, but never contain the letter "Z". Example: "Style 39500 A". Special Style numbers contain the letter "Z". When only minor changes are made in a standard machine, a "Z" is suffixed to the standard Style number. Example: "Style 39500 AZ".

Styles of machines similar in construction are grouped under a Class number, which contains no letters. Example: "Class 39500".

APPLICATION OF CATALOG

This catalog applies specifically to the standard Styles of machines as listed herein. It can also be applied with discretion to some special machines in Class 39500. All references to directions, such as right and left, front and back, etc., are taken from the operator's position while seated at the machine. Operating direction of handwheel is away from operator.

STYLES OF MACHINES

Single Curved Blade Needle, Two Looper, Three Thread, Overseaming Machine. Differential Feed, Trimming Mechanism with Spring Pressed Lower Knife, Automatic Lubricating System.

39500 A For seaming light and medium weight flat, warp, and ribbed knit fabrics of cotton, silk, or similar weight synthetics. The sewing combination has been designed especially for use on women's and children's slips, pajamas, nightgowns, or similar articles where long straight hanging seams are a primary requisite. Seam specification, 504-SSa-1; standard seam widths, 3/32 and 1/8 inch; stitch range, 8-30 per inch; cam adjusted main and differential feeds.

39500 B For seaming light and medium weight flat, warp, and ribbed knit fabrics of cotton, silk, or similar weight synthetics. The sewing combination has been designed for general purpose seaming of "T" shirts, polo shirts, panties, infants' and children's knit wear, and similar garments. Seam specification, 504-SSa-1; standard seam widths, 3/32 and 1/8 inch; stitch range, 8-30 per inch; cam adjusted main and differential feeds.

39500 P For seaming medium to heavy weight flat, warp, and ribbed knit fabrics made from cotton and wool, used on snow suits, sweat shirts, underwear and similar garments. Seam specification, 504-SSa-1, standard seam width, 1/8 inch; stitch range, 8-20 per inch; cam adjusted main and differential feeds.

39500 AF Same as 39500 P, except fitted with 39500 B sewing parts. For seaming all types and weights of flat, warp and ribbed knit cotton, wool rayon and silk fabrics. Seam specification, 504-SSa-1; standard seam widths, 3/32, 1/8 and 5/32 inch; stitch range, 8-20 per inch; cam adjusted main and differential feeds.

OILING

CAUTION! Oil was drained from machine when shipped, so reservoir must be filled before beginning to operate. Oil capacity of Class 39500 is six ounces. A straight mineral oil of a Saybolt viscosity of 200 to 250 seconds at 100° Fahrenheit should be used.

Machine is filled with oil at spring cap in top cover. Oil level is checked at sight gauge on front of machine. Red bulb on oil level indicator should show between gauge lines.

OILING (Continued)

Machine is automatically lubricated. No oiling is necessary, other than keeping main reservoir filled. Check oil daily before the morning start; add oil as required.

Drain plug screw is located at back of machine near bottom edge of base. It is a magnetic screw designed to accumulate possible foreign materials which may have entered the crank case. It should be removed and cleaned periodically.

NEEDLES

Each Union Special needle has both type and size number. The type number denotes the kind of shank, point, length, groove, finish and other details. The size number, stamped on the needle shank, denotes largest diameter of blade, measured in thousandths of an inch, midway between shank and eye. Collectively, type and size number represent the complete symbol which is given on the label of all needles packaged and sold by Union Special.

39500 A, 39500 B, 39500 P and 39500 AF use a curved blade needle. The standard needle for these styles is Type 154GAS. It is a curved blade, standard length, single groove, shallow spot, long tapered point, struck groove, chromium plated in sizes 022, 025, 027, 029, 032, 036, 040, 044.

To have needle orders promptly and accurately filled, an empty package, a sample needle, or the type and size number should be forwarded. Use description on label. A complete order would read: "1000 Needles, Type 154GAS, Size 036".

Selection of proper needle size is determined by size of thread used. Thread should pass freely through needle eye in order to produce a good stitch formation.

Success in the operation of Union Special machines can be secured only by use of needles packaged under our brand name, *Union Special* which is backed by a reputation for producing highest quality needles in materials and workmanship for more than three-quarters of a century.

CHANGING NEEDLES

Release pressure on presser foot by turning presser foot release bushing (U, Fig. 1) and swing presser arm (H) out of position. Turn handwheel in operating direction until needle is at its lowest point of travel. Using hexagonal socket wrench No. 21388 AS, furnished with machine, loosen needle clamp nut about 1/4 turn. Again turn handwheel until needle is at high position; withdraw needle.

To replace needle, leave needle holder at high position and, with the flat to the left, insert needle in holder until it rests against stop pin. Keeping needle in this position, turn handwheel until holder is again at its low point of travel; then tighten nut. Return presser arm (H) to position; re-lock presser foot release bushing (U).

THREAD STAND

After thread comes from cone on thread stand (V, Fig. 1), it is brought up through back thread eyelet, then down through front thread eyelet (W). Next it is threaded through each pair of holes in tension thread guide wire (A), down right hand hole and up through left hand hole. Then thread continues between tension discs (AD), through slot (AE), and on through thread guide (B).

THREADING

Only parts involved in threading are shown in threading diagram (Fig. 1). Parts are placed in their relative positions for clarity.

It will simplify threading this machine to follow recommended sequence of threading lower looper first, upper looper second, and needle third.

Before beginning to thread, swing cloth plate open, turn handwheel in operating direction until needle (N) is at high position, release pressure on presser foot by turning presser foot release bushing (U); and swing presser arm (H) out of position.

Be sure threads, as they come from the tension thread guide, are between tension discs (AD) and in diagonal slots (AE) in tension posts (AC).

TO THREAD LOWER LOOPER

Double end of thread and lead it through both eyes of lower looper thread eyelet (E, Fig. 1) from right to left. Note: thread must pass in front of looper thread pull-off (T). Lead thread behind fabric guard (F) and through both holes of frame looper thread guide (G). Turn handwheel in operating direction until heel of lower looper (K) is all the way to the left; then thread through both eyes from left to right. Left eye of lower looper can be threaded easily if tweezers are in left hand.

TO THREAD UPPER LOOPER

Turn handwheel until point of upper looper (L) is all the way left. Lead thread through auxiliary looper thread eyelet (D) from back to front, then through both eyes of upper looper thread eyelet (C) from left to right. Note: thread must pass in front of looper thread pull-off (T). After pulling up upper looper thread tube assembly (M), lead thread under neck of top cover casting and down through thread tube assembly (M). Pull thread out bottom of tube; push tube down, then insert thread through upper looper eye from front to back.

CAUTION! Be sure upper looper thread is under lower looper thread when passing from tube assembly to upper looper eye.

TO THREAD THE NEEDLE

Turn handwheel in operating direction until needle (N, Fig. 1) is at its highest position. Insert needle thread from right to left, through both eyes of needle thread eyelet (R), under neck of top cover casting; then down through hole in top cover needle thread eyelet (P). Thread needle from front.

THREAD TENSION

The amount of tension on needle and looper threads is regulated by three knurled tension nuts (AA, Fig. 1). Tension on threads should be only enough to secure proper stitch formation.

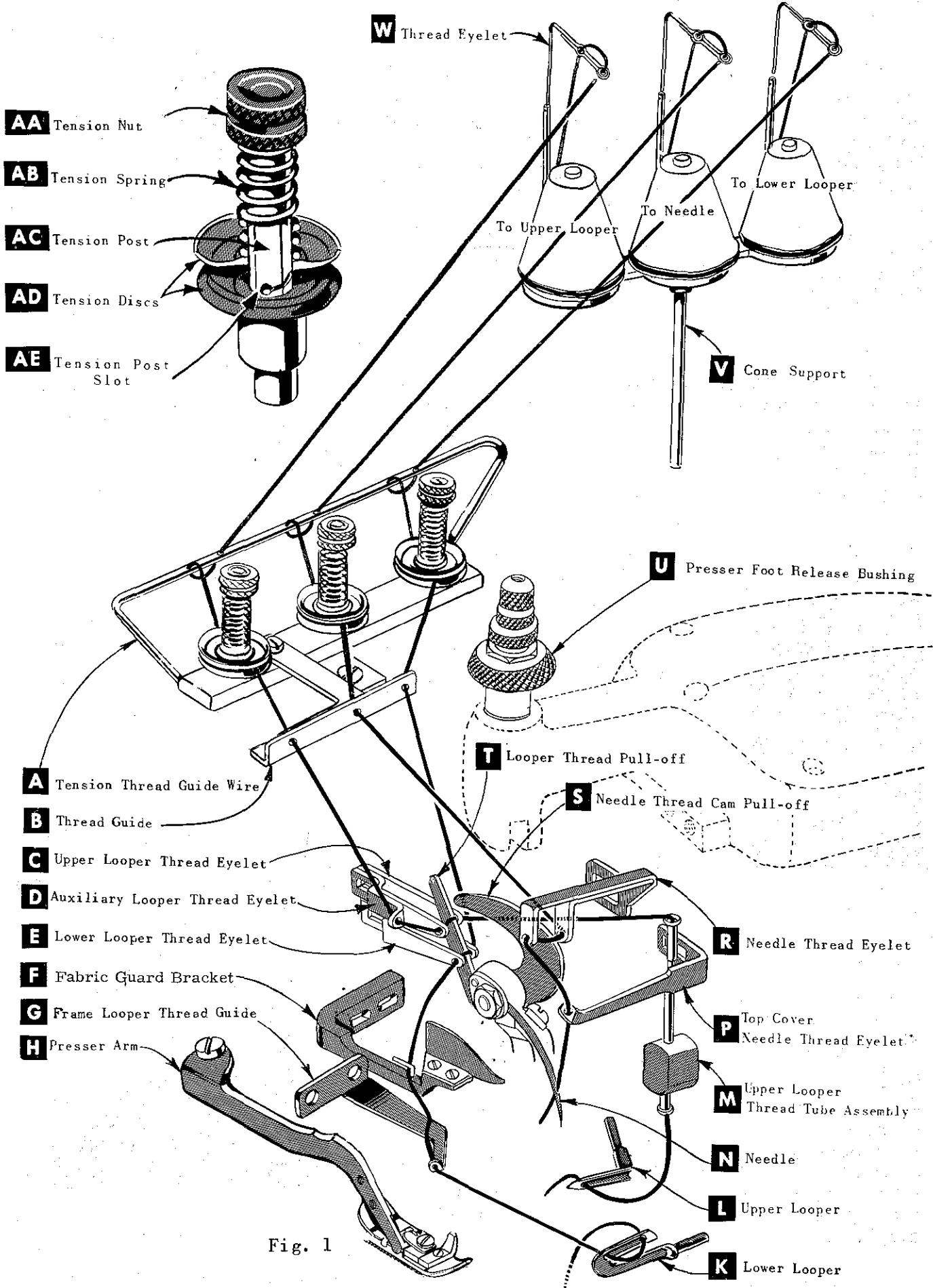

Fig. 1

PRESSER FOOT PRESSURE

Sufficient pressure to feed work uniformly should be maintained. Should it be necessary to increase or decrease amount of pressure on presser foot, loosen lock nut (A, Fig. 2) and turn adjusting screw (B). Adjusting screw has a right hand thread so tightening increases pressure, loosening decreases pressure. When pressure adjusting screw (B) has been properly set, tighten lock nut (A). With presser foot resting on throat plate, position locking nut (C) so that its under surface is approximately 1/32 inch to 1/16 inch from the top surface of adjusting screw (B). Set cap (D) against locking nut (C).

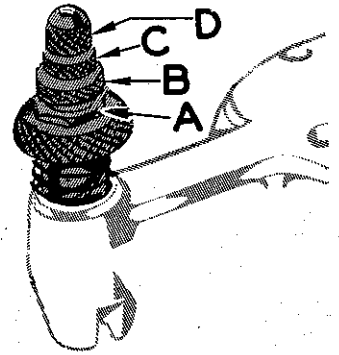

Fig. 2

FEED ECCENTRICS

Feed eccentrics used in these machines have been selected to produce approximately 12 stitches per inch. It will be noted that the part number of main feed eccentric is No. 39540-12 while that of differential feed eccentric is No. 39540-10. Minor numbers of the part symbol indicate approximately the number of stitches obtainable when using that eccentric. Unless otherwise specified, machine will be shipped with above combination of eccentrics.

Generally speaking, differential (right hand) feed eccentric determines number of stitches produced; main (left hand) feed eccentric is selected in relation to degree and direction of stretch of material being sewn, or type of operation.

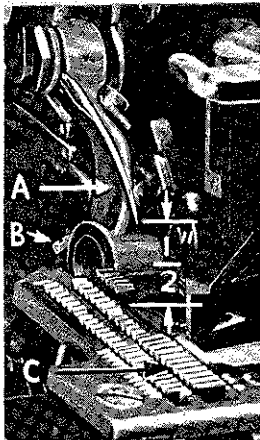

Fig. 3

Following stitch number feed eccentrics are available under No. 39540- 4, 5, 6, 7, 8, 9, 10, 11, 12, 13, 14, 15, 16, 18, 20, 22, 24, 26, 28, 30, 32, 34, 36, 40. Only two eccentrics are supplied with each machine. Additional eccentrics may be ordered separately. To order an eccentric, use No. 39540 with a minor number suffixed to indicate number of stitches desired. Example: "39540-12".

ASSEMBLING AND ADJUSTING SEWING PARTS

Before assembling sewing parts, remove cloth plate, fabric guard, chip guard, upper knife assembly, lower knife holder assembly, then follow this suggested sequence:

SETTING THE NEEDLE

With throat plate in position, needle should center in the front end of needle slot. When needle is at high position, needle point should be set 1/2 inch above throat plate (Fig. 3). Move needle driving arm (A, Fig. 3) by loosening clamp screw (B). Remove throat plate.

If needle thread cam pull-off (A, Fig. 4) overlaps looper thread pull-off (B), separate by moving looper thread pull-off back. When retightening looper pull-off screw, be sure to take up end play in needle driving arm.

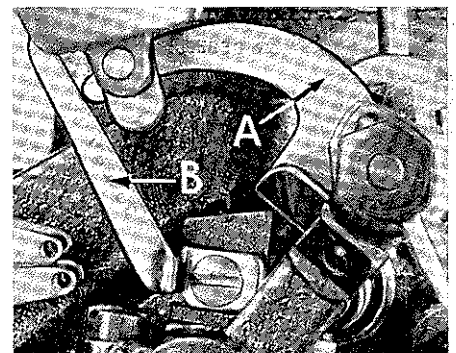

Fig. 4

SETTING THE NEEDLE (Continued)

At this point, insert lower looper (A, Fig. 6) into bar (B). With lower looper at left end of its stroke, set looper point $\frac{1}{8}$ inch from center of needle (Fig. 6), using looper gauge No. 21225-1/8. Do not have lower looper deflecting needle. Tighten nut.

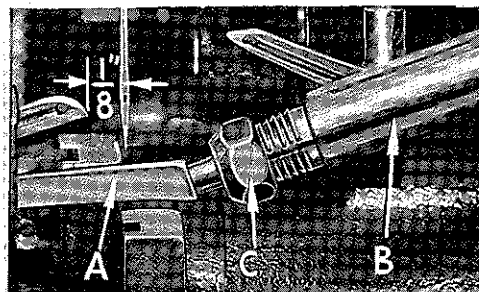

Fig. 6

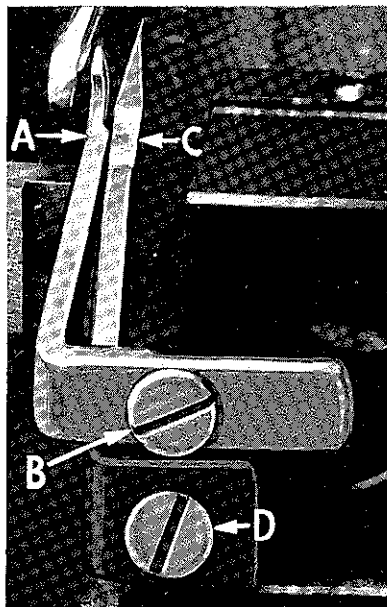

Fig. 5

Now assemble differential (front) feed dog.

SETTING THE REAR NEEDLE GUARD

Set rear needle guard (A, Fig. 5) as high as possible, without interfering with either lower looper or movement of lower knife holder, but still in position to deflect needle forward $-.002 - .004$ inch. Screw (B) is used to set rear needle guard. Make sure there is no interference between rear needle guard and lower looper.

SETTING THE LOWER LOOPER

Now finish lower looper adjustment. As lower looper moves to the right, its point should be set into the needle scarf (A, Fig. 7) until the needle springs forward from rear guard surface another $.002 - .004$ inch.

SETTING THE FRONT NEEDLE GUARD

Assemble front needle guard (C, Fig. 5). When lower looper is springing needle off back guard, set front needle guard as close as possible to needle without touching. Screw (D) is used to adjust and set front needle guard. After this setting make sure there is no interference between needle guards and differential feed dogs.

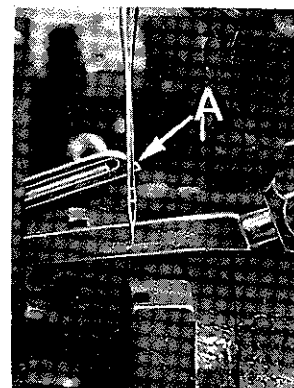

Fig. 7

SETTING THE UPPER LOOPER

Insert upper looper (A, Fig. 8) in its holder. Screw (B, Fig. 8) holds upper looper in its holder, and permits it to be pushed in or out or turned around its shank. Insert upper looper holder into upper looper shaft, if it is not already in place. Screw (C, Fig. 8) on clamp holds the upper looper holder in the shaft. Locate upper looper in its holder so that the shank extends $\frac{1}{16}$ to $\frac{3}{32}$ inch beyond holder (Fig. 8).

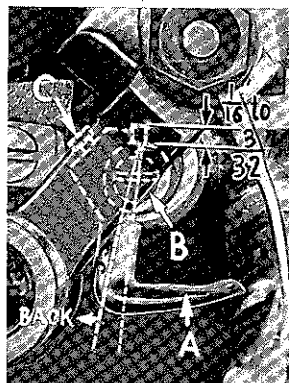

Fig. 8

When the upper looper is at the right end of its stroke, upper looper holder should be set to position upper looper shank back of vertical on 39500 A and B (Fig. 8).

SETTING THE UPPER LOOPER (Continued)

NOTE: On Styles 39500 P and AF, the upper looper holder should be set to position the upper looper shank about vertically. Be sure, on all styles, there is a clearance between heel of looper and casting. By adjusting looper holder in or out of upper looper shaft and by turning the looper around its shank, set upper looper point to cross lower looper to the left of the lower looper eye with 0.002 to 0.004 clearance (Fig. 9).



Fig. 9

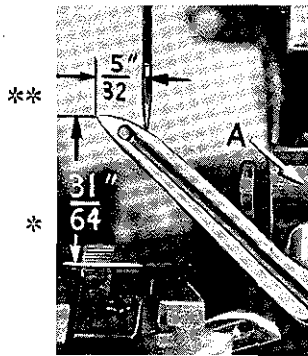

Fig. 10

Next, turn handwheel until looper is at the left end of its travel; check dimensions of upper looper point with respect to needle and throat plate (Fig. 10). If resetting is necessary, do it by moving the upper looper holder (A, Fig. 10). Figure 10 represents the dimensional setting for Styles 39500 A and B.

NOTE: For Styles 39500 P and AF, the settings are $\ast 1/2$ and $\ast\ast 9/64$. For example, dimension $31/64$ inch is increased by turning upper looper holder counterclockwise looking from left end of machine; dimension $5/32$ inch is increased by pulling upper looper holder left, out of upper looper shaft. After these changes are made, it may be necessary to turn upper looper around its shank slightly to maintain the condition shown in Fig. 9.

When the correct setting is obtained, it can be checked quickly as follows: As upper looper is moving to the right, when upper looper eye centers on the needle, bottom of the needle eye should be about level with top surface of upper looper (Fig. 11) for Styles 39500 A and B.

NOTE: For Styles 39500 P and AF, the eyes of the upper looper and needle should align exactly.

Check setting to avoid interference between upper looper and needle on needle downstroke. If needle rubs the back of upper looper, pull looper out of its holder slightly and rotate looper a short distance counterclockwise, looking from left end of machine. Reset to maintain dimensions of Figs. 9, 10, 11.

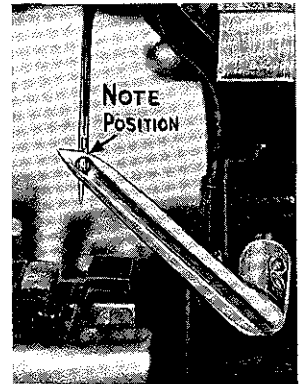

Fig. 11

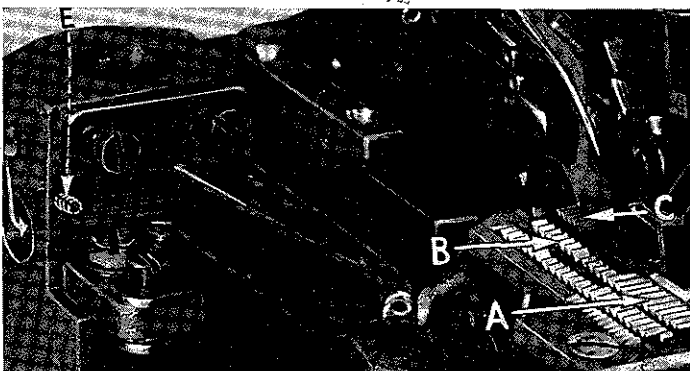

Fig. 12

SETTING THE FEED DOGS

On Style 39500 A, set all three feed dogs (A, B, C, Fig. 12) so the top surfaces of teeth all lay in the same plane. This can be checked by sighting across teeth with a straight edge. Feed dogs should now be leveled with throat plate surface by rotating feed tilting adjusting pin (D). This pin raises or lowers the back end of both feed bars at the same time.

SETTING THE FEED DOGS (Continued)

The feed dogs should be set level at the time teeth first appear above the throat plate. Screw (E) locks feed tilting adjusting pin in place. Now set feed dogs so that teeth rise about 3/64 inch above throat plate.

NOTE: On Styles 39500 B, P and AF, set chaining feed dog (C) level with top of throat plate when dog is at top of its travel.

SETTING THE LOWER KNIFE

Replace lower knife holder assembly. Lower knife (A, Fig. 13) should be set with cutting edge flush with throat plate surface. Adjustments are made with hexagonal head screw which holds lower knife. Lower knife is spring pressed against upper knife, so no lateral adjustment is necessary when width of trim is changed.

Lower knife may be secured in any position by tightening screw (B) and locking nut (C) against support bracket. Because screw (B) also serves as latch pin for the cloth plate latch spring, it should always be locked with nut (C) even when screw is not tightened against lower knife holder.

SETTING THE UPPER KNIFE

Replace upper knife assembly. Clamp upper knife (D, Fig. 13) in position, setting nut (E) to hold clamp (F) in its most clockwise position against upper knife. At bottom of its stroke, front cutting edge of upper knife should extend not less than 1/64 inch below cutting edge of lower knife. The chain guard (J) should be set down against the upper knife and slightly back from the cutting edge.

After upper knife has been set for proper width of trim, screw (G) should be tightened to lock upper knife holding block (H) in place. This will simplify resetting when upper knife is replaced.

SETTING THE STITCH LENGTH

Length of stitch is determined by the combination of feed eccentrics used. Outer (left) eccentric (A, Fig. 14) actuates main (rear) feed dog; while the inner (right) eccentric (B) actuates the differential (front) feed dog.

In assembling feed eccentrics, be sure hubs are facing each other. Be careful not to damage shaft or key. Tighten nut (C) securely. Be sure wool yarn in oil tube (F) touches feed eccentric connections.

To change feed eccentrics, remove nut (C) from end of shaft (D). Turn handwheel in operating direction until key slot in eccentric is toward front. Using hooked eccentric extractor (E), supplied with machine, reach behind eccentrics as shown and withdraw eccentrics. It may be necessary to move handwheel back and forth slightly during extraction.

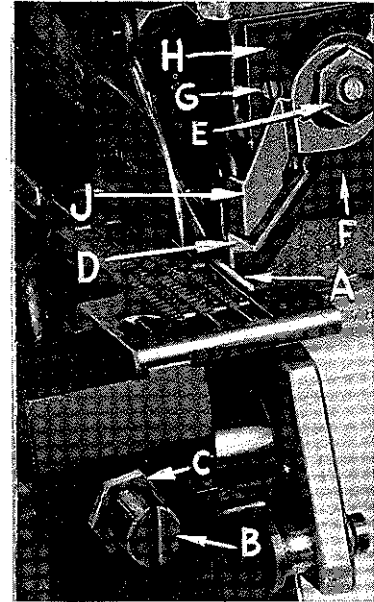

Fig. 13

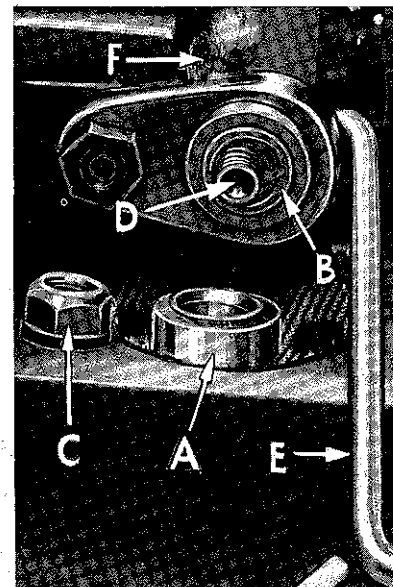

Fig. 14

SETTING THE STITCH LENGTH (Continued)

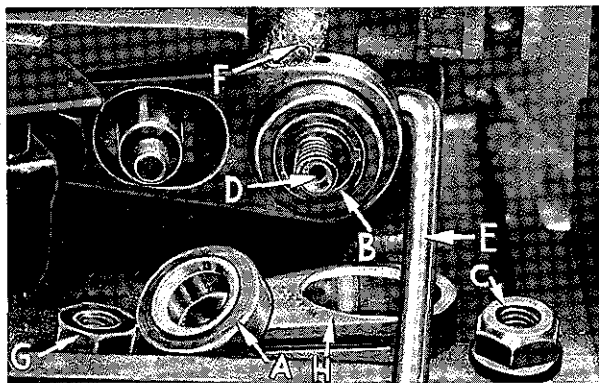

Fig. 15

Foot lifter lever arm (A, Fig. 16) and collar (B) secure the shaft. Be sure presser arm does not bind and rise when presser foot release bushing is unlocked. To center presser foot and stitch tongue with respect to throat plate needle hole, loosen presser foot hinge screw.

Adjust lifter lever stop screw (C) so that presser foot can be raised no higher than upper looper will permit; then, lock nut (D). To find this maximum safe position, turn the handwheel so point of upper looper is directly over presser foot tongue. Raise presser foot by depressing the presser foot treadle and manually lower the toe of foot. Height adjustment is correct if presser foot tongue does not contact the upper looper. There should be from 1/16 to 1/8 inch free motion of foot lifter lever before presser foot begins to rise. This adjustment is made with screw (E), locked with nut (F).

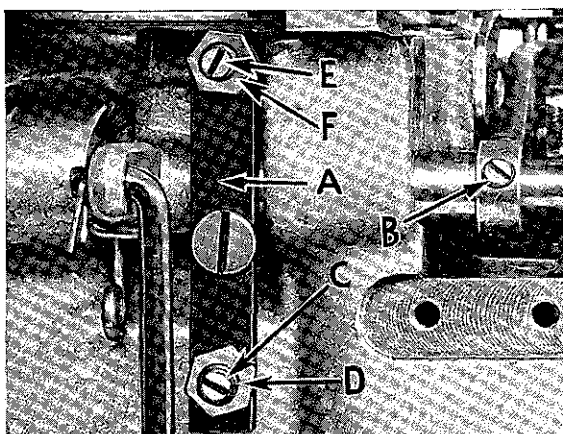

Fig. 16

Finally, re-assemble chip guard, fabric guard, cloth plate.

STARTING TO OPERATE

Be sure machine is threaded according to threading diagram (Fig. 1, page 7). With thread tensions light, set looper thread eyelets (C & E) about horizontal and in the middle of their front to back locations. Operate machine slowly, without presser foot in place, to make sure that chain forms and moves off the tongue freely. Swing presser foot into position, insert material, and sew slowly.

NEEDLE THREAD CONTROL

While sewing on material, check needle thread control as follows: Usually all needle thread is drawn on needle down stroke. At top of needle stroke, thread should be just tight enough to feed chain off stitch tongue. Stitch tends to pull down slightly if excessive thread is pulled on the up stroke. With needle at bottom of stroke, position needle thread eyelet (R, Fig. 1) so that needle thread cam pull-off (S) just contacts needle thread.

NEEDLE THREAD CONTROL (Continued)

On Styles 39500 P and AF, it is desirable to adjust the needle thread pull-off eyelet well-forward (toward the operator) to delay, slightly, the tightening of the needle thread.

LOWER LOOPER THREAD CONTROL

With material under presser foot, set lower looper thread eyelet (E, Fig. 1) back far enough so thread is a little slack when looper thread pull-off (T) reaches its most rearward position. Looper thread pull-off (T) is set about 1/8 inch distance behind needle thread cam pull-off (S). Frame looper thread guide (G) should be set with its left hand eyelet approximately 1/8 inch right of lower looper (K) heel eyelet at the time lower looper is at extreme left end of its travel.

While sewing on material, check drawing off of looper thread as follows: A portion of lower looper thread should be drawn through the tension before lower looper thread comes off upper looper. To increase amount of thread drawn through the tension while lower looper thread is on upper looper, move lower looper thread eyelet (E) down, keeping the same amount of pull-off action.

UPPER LOOPER THREAD CONTROL

Before proceeding to adjust upper looper thread eyelet (C, Fig. 1) balance all three tensions to give a normal appearing stitch. Moderate change in these tensions will not markedly effect the purl.

During needle down stroke, forward stroke of looper thread pull-off (T) will draw upper looper thread through the tension. When normal amount of looper thread is drawn, upper looper thread will have almost all slack taken up as looper thread pull-off reaches its most rearward position.

POSITIONING THE PURL

To move the purl more under the edge, both looper thread eyelets (C & E, Fig. 1) should be raised keeping the same amount of pull-off. Usually it is better to have slightly more pull-off on upper thread than on lower thread.

If it becomes necessary to move looper thread pull-off (T), be sure to take up all end play in needle drive shaft before tightening. If upper looper is located so that it is higher over throat plate than recommended in (Fig. 10), the purl will tend to form near top edge. If upper looper is too low, the purl will form nearer bottom edge.

THREAD TENSIONS

The needle thread tension required is a function of needle thread and material being sewn. In general, lower looper thread tension should be set as high as possible without causing needle thread to be pulled down. Upper looper thread tension should be increased as long as the elasticity of the chain increases, or until the purl is pulled too far over the top.

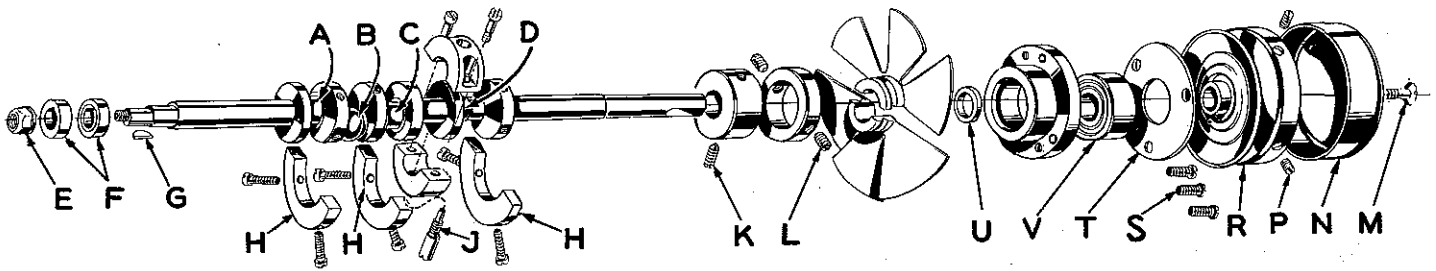

Fig. 17

TO REMOVE CRANKSHAFT

Crankshaft can be withdrawn easier if these steps are followed:

1. Drain oil by removing plug screw located on back of machine near bottom edge of base.
2. Remove top and bottom covers of machine.
3. Remove feed eccentric nut (E, Fig. 17) and, with the aid of the eccentric extractor, slip off the eccentrics (F).
4. Remove key (G).
5. Remove three counterweights (H). Identify these counterweights so that they will be re-assembled in the proper places.
6. Remove screw (J) which holds crankshaft split bearing. This screw is reached through bottom of bed casting.
7. Remove caps of bearings on crankshaft at points A, B, and D. When re-assembling bearing caps make sure they are in their original position. Trade marks are stamped on both halves of the caps and both trade marks should be on the same side of the bearings. Also, screws should be re-assembled in the same holes from which they were removed.
8. Loosen clamp nut (A, Fig. 18) which holds upper knife driving arm (B). Access to clamp nut is through top cover. Draw driving arm to the left until upper knife driving lever (C) and connecting rod (D) drop, allowing removal of bearing cap (E). This is at bearing point (C, Fig. 17) on crankshaft. Observe same precautions when re-assembling cap as described in 7 above.
9. Remove screw (K, Fig. 17) which holds inner right crankshaft bearing. This screw is reached through bottom of bed casting.
10. Loosen two screws (L) in fan collar; remove both halves of cooling fan.
11. Remove screw (M); take off pulley cap (N).
12. Loosen two screws (P); remove pulley (R).
13. Remove three screws (S); take off bearing retaining plate (T).
14. Crankshaft may now be removed.
15. If necessary to replace ball bearing (V), it should be pressed off shaft on an arbor press. In replacing bearing it must be pressed on carefully until it seats against ground thrust washer (U).
16. Carefully observing reverse of the foregoing operations should simplify re-assembly of crankshaft. Checking exploded view drawings for location of various parts and constant testing for binds during re-assembly will also prove helpful.
17. Before re-assembling, thoroughly clean and dry top and bottom covers and gaskets. Before re-assembling bottom cover make sure that spring pressed oil wick which lubricates left crankshaft bearing is inserted in hole in casting and that it contacts shaft. The wick stands vertically on its spring against bottom cover. Coat oil drain plug with a sealing compound before re-assembling to prevent oil leakage. No. 1 Crane Lead Seal is recommended.

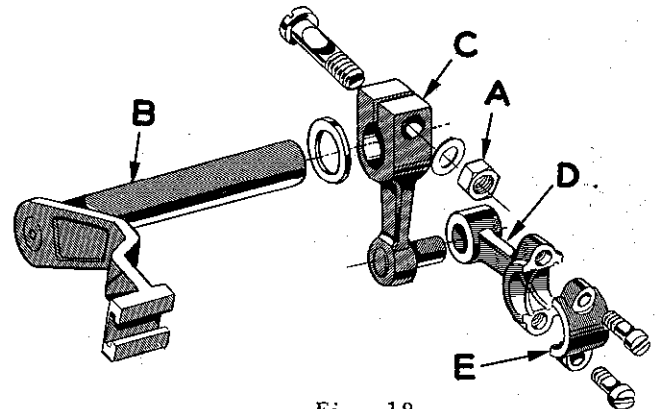

Fig. 18

ORDERING REPAIR PARTS

ILLUSTRATIONS

This catalog has been arranged to simplify ordering repair parts. Exploded views of various sections of the mechanism are shown so that the parts may be seen in their actual position in the machine. On the page opposite the illustration will be found a listing of the parts with their part numbers, description and the number of pieces required in the particular view being shown.

Numbers in the first column are reference numbers only, and merely indicate the position of that part in the illustration. Reference number should never be used in ordering parts. Always use the part number listed in the second column.

Component parts of sub-assemblies which can be furnished for repairs are indicated by indenting their descriptions under the description of the main sub-assembly. Example:

41	29126 DF	Lower Looper Drive Lever Connecting Rod Assembly -----	1
42	22729 D	Screw, for No. 39544 N-----	2
42 A	22729 E	Screw, for No. 39544 N-----	2
43	97	Screw, for No. 39544 S -----	1
44	39544 S	Ball Joint Guide Fork-----	1
45	39544 U	Lower Looper Bar Driving Lever -----	1

It will be noted in the above example that the eccentric, ball stud, and bearing are not listed. The reason is that replacement of these parts individually is not recommended, so complete sub-assembly should be ordered.

Where parts for Styles 39500 A, 39500 B, 39500 P and 39500 AF are not the same, the difference will be shown in the illustrations or mentioned in the descriptions. When a part is used in all machines covered by this catalog no machine style will be mentioned.

At the back of the book will be found a numerical index of all the parts shown in this book. This will facilitate locating the illustration and description when only the part number is known.

IDENTIFYING PARTS

Where the construction permits, each part is stamped with its part number. On some of the smaller parts, and on those where construction does not permit, an identification letter is stamped in to distinguish the part from similar ones.

PART NUMBERS REPRESENT THE SAME PART, REGARDLESS OF CATALOG IN WHICH THEY APPEAR.

USE GENUINE NEEDLES AND REPAIR PARTS

Success in the operation of these machines can be secured only with genuine Union Special Needles and Repair Parts as furnished by the Union Special Machine Company, its subsidiaries and authorized distributors. They are designed according to the most scientific principles, and are made with utmost precision. Maximum efficiency and durability are assured.

Genuine needles are packaged with labels marked *Union Special*. Genuine repair parts are stamped with the Union Special trade mark. Each trade mark is your guarantee of the highest quality in materials and workmanship.

TERMS

Prices are net cash and subject to change without notice. All shipments are forwarded f. o. b. shipping point. Parcel post shipments are insured unless otherwise directed. A charge is made to cover postage and insurance.

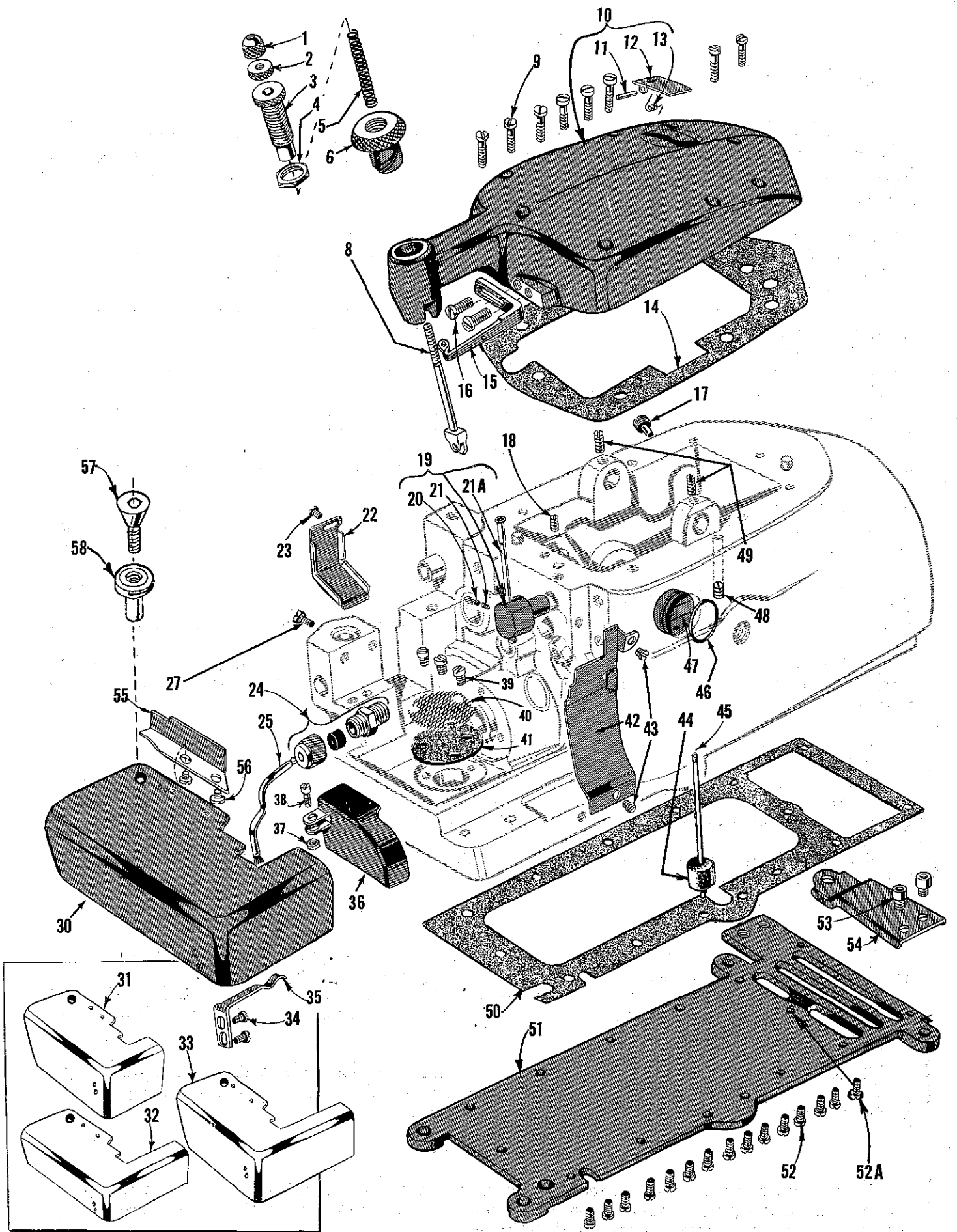

MAIN FRAME, MISCELLANEOUS COVERS, PLATES

Ref. No.	Part No.	Description	Amt. Req.
1	39557 B	Presser Spring Plunger Cap Nut -----	1
2	39557 E	Presser Spring Plunger Locking Nut -----	1
3	39557 C	Presser Spring Plunger Adjusting Screw-----	1
4	39557 F	Lock Nut - Adjusting Screw -----	1
5	39557	Presser Spring -----	1
6	39556 A	Presser Foot Release Bushing-----	1
8	39557 A	Presser Spring Plunger-----	1
9	22541	Screws - Top Cover -----	8
10	39582 S	Top Cover-----	1
11	51-103 Blk	Hinge Pin -----	1
12	39582 L	Oil Filler Cover -----	1
13	39582 V	Spring -----	1
14	39582 AA	Top Cover Gasket -----	1
15	39563 F	Top Cover Needle Thread Eyelet-----	1
16	22569 B	Screw - Eyelet-----	2
17	22571 E	Magnetic Oil Drain Plug Screw -----	1
18	22565	Screw - Upper Looper Thread Tube Assembly-----	1
19	29477 GW	Upper Looper Thread Tube Assembly -----	1
20	22743	Screw - Tube Tension Spring -----	1
21	39568 J	Looper Thread Tube Tension Spring-----	1
21 A	39568 G	Thread Tube-----	1
22	39534 R	Feed Bar Oil Shield -----	1
23	90	Screw - Feed Bar Oil Shield-----	1
24	660-234	Oil Tube Coupling -----	1
25	39594	Feed Bar Connecting Rod Oil Tube -----	1
27	22569	Screw - Cloth Plate Stud -----	1
30	39501 A	Cloth Plate, semisubmerged installation-----	1
31	39501	Cloth Plate, nonsubmerged installation -----	1
32	39501 C	Cloth Plate, semisubmerged installation-----	1
33	39501 B	Cloth Plate, nonsubmerged installation -----	1
34	90	Screws - Latch Spring -----	2
35	39532 A	Cloth Plate Latch Spring -----	1
36	39582 D	Feed Mechanism Cover -----	1
37	41071 G	Nut - Feed Mechanism Cover-----	1
38	86 X	Screw - Feed Mechanism Cover -----	1
39	22569 A	Screws - Oil Screen and Strainer -----	3
40	39594 G	Oil Filter Screen-----	1
41	39594 H	Oil Strainer -----	1
42	39578 B	Chip Guard -----	1
43	22569 D	Screws - Chip Guard -----	2
44	39593 C	Oil Gauge Float -----	1
45	39593 D	Oil Gauge Indicator-----	1
46	660-243	Oil Gauge Seal Ring -----	1
47	39593 E	Oil Sight Gauge, -----	1
48	22894 AD	Screws - Lower Looper Bar Drive Lever Shaft -----	2
49	22565	Screws - Upper Looper Drive Lever Shaft -----	2
50	39582 Y	Bottom Cover Gasket -----	1
51	39582 X	Bottom Cover-----	1
52	22569 C	Screws - Bottom Cover -----	14
52A	22586 R	Screw - Bottom Cover -----	1
53	22653 D-4	Screws - Bottom Cover Extension-----	2
54	39582 F	Bottom Cover Extension -----	1
55	39578 F	Cloth Plate Fabric Guard -----	1
56	138	Screw - Cloth Plate Fabric Guard-----	2
57	22657 D-12	Screw - Cloth Plate -----	1
58	39501 K	Stud - Cloth Plate -----	1

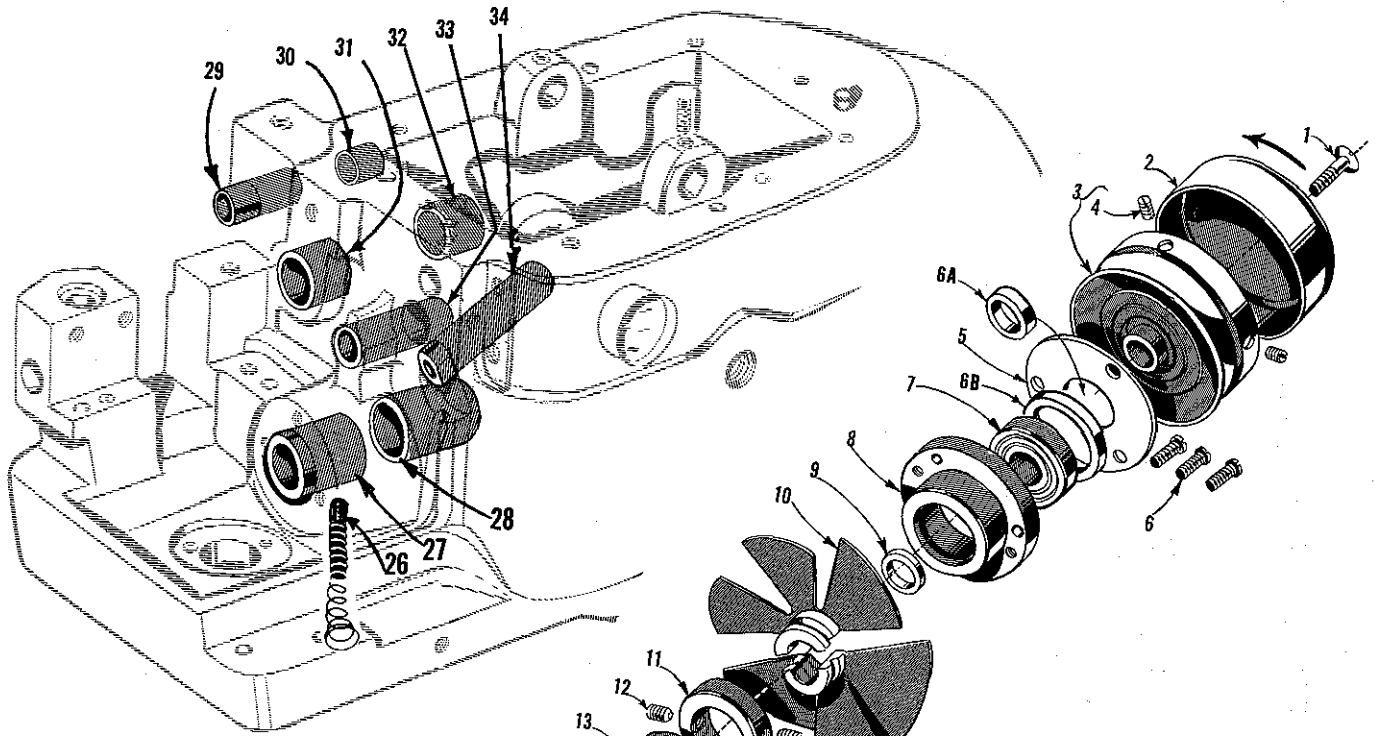

- A - NEEDLE DRIVE BEARING
- B - SPREADER - UPPER LOOPER DRIVE BEARING
- C - UPPER KNIFE DRIVE BEARING
- D - LOWER LOOPER DRIVE BEARING

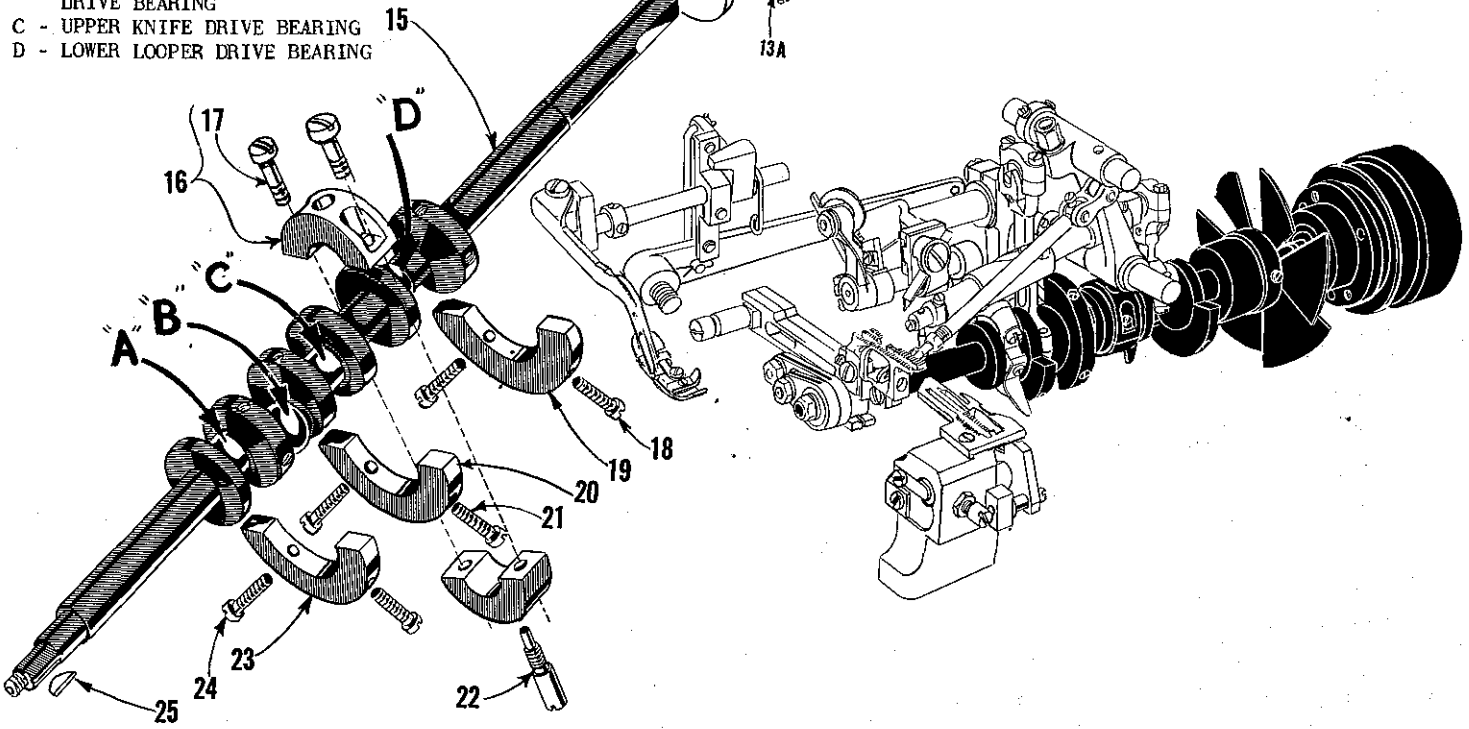

CRANKSHAFT MECHANISM AND BUSHINGS

<u>Ref. No.</u>	<u>Part No.</u>	<u>Description</u>	<u>Amt. Req.</u>
1	22769 A	Screw, for pulley cap -----	1
2	39521 A	Pulley Cap-----	1
3	39521	Pulley-----	1
4	95	Screw-----	2
5	39590 H	Crankshaft Ball Bearing Retaining Plate -----	1
6	22569	Screw -----	3
6A	39590 S	Spacer Collar -----	1
6B	39590 R	Ball Bearing Stop Collar -----	1
7	660-268	Crankshaft Ball Bearing-----	1
8	39590 G	Crankshaft Ball Bearing Housing -----	1
9	39590 J	Thrust Washer -----	1
10	39591 G	Crank Chamber Cooling Fan -----	1
11	39591 H	Crank Chamber Cooling Fan Collar-----	1
12	22894 D	Screw -----	2
13	39590 K	Crankshaft Bearing, inner right-----	1
13A	22565 F	Screw -----	1
14	39590 P	Oil Slinger Collar -----	1
14A	77 Q	Screw-----	2
15	39522 C	† Crankshaft, for Styles 39500 A & B-----	1
	39522 B	* Crankshaft, for Styles 39500 P & AF -----	1
16	39590 D	Crankshaft Split Bearing -----	1
17	97 A	Screw, for split bearing -----	2
18	22747 B	Screw, for crankshaft counterweight-----	2
19	39591 B	Crankshaft Counterweight, right -----	1
20	39591 A	Crankshaft Counterweight, middle-----	1
21	22747 B	Screw, for crankshaft counterweight-----	2
22	39590 N	Stud, for crankshaft split bearing -----	1
23	39591	Crankshaft Counterweight, left-----	1
24	22747 B	Screw, for crankshaft counterweight-----	2
25	39541	Feed Driving Eccentric Key -----	1
26	666-94	Oil Wick and Spring-----	1
27	39590	Crankshaft Bushing, left -----	1
28	39590 T	Crankshaft Bushing, inner left -----	1
29	39555 E	Foot Lifter Shaft Bushing, left -----	1
30	39142 G	Foot Lifter Shaft Bushing, right-----	1
31	39573 K	Upper Knife Driving Arm Bushing, left -----	1
32	39573 L	Upper Knife Driving Arm Bushing, right -----	1
33	39552 N	Needle Driving Arm Crank Bushing-----	1
34	39544 L	Lower Looper Bar Bushing -----	1

NOTE:

† DISCONTINUED - For repairs order No. 29477 JA.
 * DISCONTINUED - For repairs order No. 29477 JP.

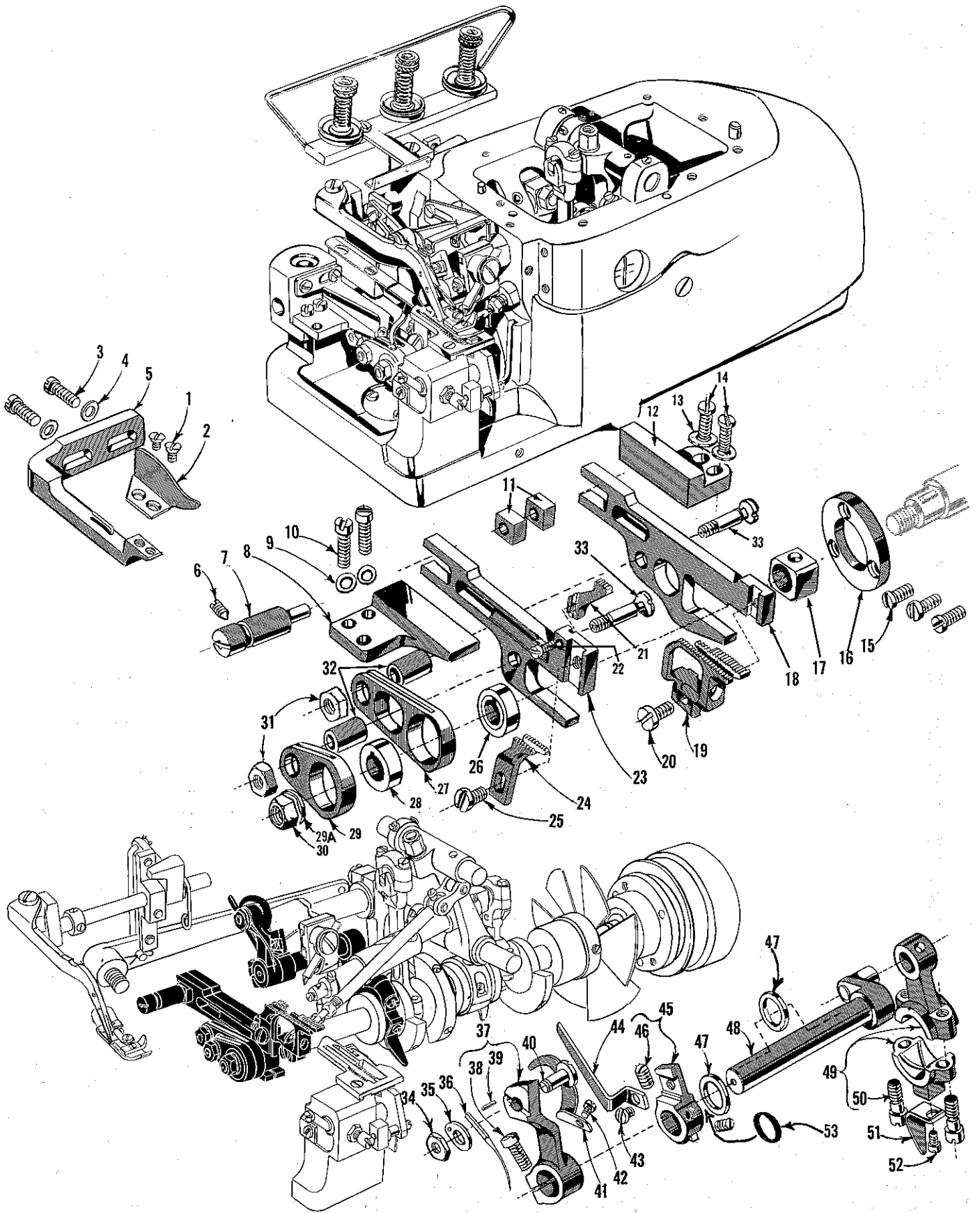

NEEDLE DRIVE AND FEED MECHANISM

Ref. No.	Part No.	Description	Amt. Req.
1	87	Screws - Fabric Guard -----	2
2	39578 R	Fabric Guard-----	1
3	22569 B	Screws - Mounting Bracket -----	2
4	8372 A	Mounting Bracket Washers-----	2
5	39578 P	Fabric Guard Mounting Bracket -----	1
6	22565 F	Screw - Adjusting Pin-----	1
7	39535 C	Feed Tilting Adjusting Pin-----	1
8	39535	Main Feed Bar Guide, left-----	1
9	53634 C	Feed Bar Guide Washer, left-----	2
10	22569	Screws - Feed Bar Guide, left-----	2
11	39535 B	Feed Bar Guide Blocks-----	2
12	39535 D	Differential Feed Bar Guide, right-----	1
13	53634 C	Feed Bar Guide Washers, right-----	2
14	22569 B	Screws - Feed Bar Guide, right-----	2
15	22569 G	Screws - Thrust Washer-----	3
16	39534 H	Differential Feed Bar Thrust Washer -----	1
17	39538	Feed Lift Block-----	1
18	39534 G	Differential Feed Bar -----	1
19	39526 B	Differential Feed Dog, for Styles 39500 A, B & AF, 16 teeth to inch-----	1
	39526 P	Differential Feed Dog, for Style 39500 P, 12 teeth to inch-----	1
	*39526 D	Same as 39526 B, except 20 teeth to inch-----	1
20	22528	Screw - Differential Feed Dog-----	1
21	39505 C	Chaining Feed Dog, marked "C", for Style 39500 A-----	1
	39505	Chaining Feed Dog, for Style 39500 B & AF-----	1
	39505 E	Chaining Feed Dog, for Style 39500 P-----	1
22	22797 A	Screw - Chaining Feed Dog-----	1
23	39534	Main Feed Bar-----	1
24	39505 B	Main Feed Dog, marked "B", for Styles 39500 A, B & AF, 16 teeth to inch-----	1
	39505 P	Main Feed Dog, marked "J", for Style 39500 P, 12 teeth to inch-----	1
	*39505 D	Same as 39505 B, except 20 teeth to inch, marked "E"-----	1
25	93 A	Screw - Main Feed Dog-----	1
26	39540 B-10	Differential Feed Driving Eccentric, .022 inch throw-----	1
27	39536 A	Differential Feed Bar Driving Connection-----	1
28	39540 B-12	Main Feed Driving Eccentric, .006 inch throw-----	1
29	39536 Z	Main Feed Bar Driving Connection-----	1
29A	20	Washer - Crankshaft-----	1
30	18	Nut - Crankshaft-----	1
31	39536 E	Nuts - Feed Bar Driving Studs-----	2
32	39536 C	Feed Bar Driving Connections Bushings-----	2
33	39536 B	Feed Bar Driving Studs-----	2
34	14077	Nut - Needle Clamp Stud-----	1
35	39551 A	Needle Clamp Washer-----	1
36	154 GAS	Needle-----	1
37	39552	Needle Driving Arm-----	1
38	22596 E	Screw - Needle Driving Arm-----	1
39	50-774 Blk.	Stop Pin - Needle Driving Arm-----	1
40	39551 F	Needle Clamp Stud-----	1
41	39563 G	Needle Thread Cam Pull-off-----	1
42	28	Screw - Needle Thread Cam Pull-off-----	1
43	22564	Screw - Looper Thread Pull-off-----	1
44	39568 A	Looper Thread Pull-off-----	1
45	39568 Y	Looper Thread Pull-off Lever-----	1
46	88 B	Screw - Looper Thread Pull-off Lever-----	2
47	39552 C	Needle Driving Arm Crank Thrust Washer-----	2
48	39552 A	Needle Driving Arm Crank-----	1
49	39552 E	Needle Driving Arm Crank Connecting Rod-----	1
50	22587 J	Screws - Connecting Rod-----	2
51	39594 N	Oil Splasher-----	1
52	77	Screw - Oil Splasher-----	1
53	660-207	Oil Ring Seal - Needle Driving Arm Crank-----	1

* Available as extra send and charge item.

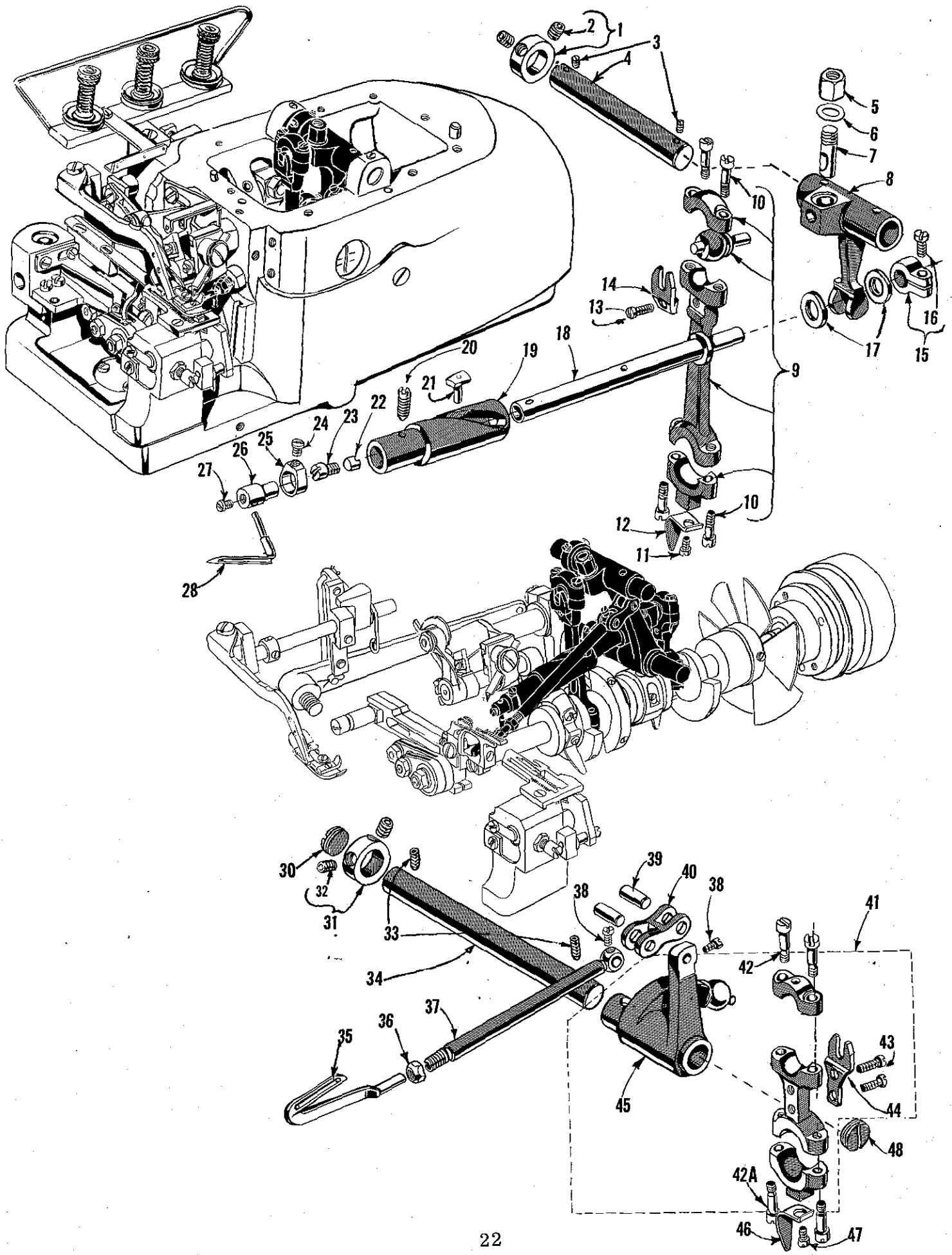

UPPER AND LOWER LOOPER DRIVING PARTS

<u>Ref. No.</u>	<u>Part No.</u>	<u>Description</u>	<u>Amt. Req.</u>
1	482 C	Upper Looper Shaft Collar -----	1
2	22894 C	Screws - Collar -----	2
3	22565	Screws - Upper Looper Drive Lever Shaft-----	2
4	7446 A	Upper Looper Drive Lever Shaft -----	1
5	1280	Nut - Locking Stud -----	1
6	39543 R	Locking Stud Washer-----	1
7	43143 N	Locking Stud - Upper Looper Drive Lever-----	1
8	39543 H	Upper Looper Drive Lever -----	1
9	29126 CG	Upper Looper Drive Lever Connecting Rod Assembly----	1
10	22559 A	Screws - Connecting Rod Assembly -----	4
11	77	Screw - Oil Splasher -----	1
12	39594 N	Oil Splasher -----	1
12 A	666-255	Felt Plug, for connecting rod -----	1
13	22747	Screw - Guide Fork -----	1
14	41255 B	Ball Joint Guide Fork - Upper Looper Drive Assembly --	1
15	39543 M	Collar Clamp -----	1
16	22562 A	Screw - Collar Clamp-----	1
17	39543 P	Upper Looper Shaft Thrust Washers -----	2
18	39543 K	Upper Looper Shaft -----	1
19	39543 S	Bushing and Cam Guide-----	1
20	22565 H	Screw - Cam Guide -----	1
21	39543 T	Cam Follower -----	1
22	39543 E	Cam Follower Locking Clamp-----	1
23	22503 F	Screw - Locking Clamp -----	1
24	22 KH	Screw - Upper Looper Holder Collar -----	1
25	39543 A	Upper Looper Holder Collar -----	1
26	39543	Upper Looper Holder -----	1
27	22564 G	Screw - Upper Looper Holder-----	1
28	39508 A	Upper Looper -----	1
30	22539 K	Plug Screw - Lower Looper Shaft -----	1
31	482 C	Lower Looper Shaft Collar -----	1
32	22894 C	Screws - Collar -----	2
33	22894 AD	Screws - Lower Looper Bar Driving Lever Shaft-----	2
34	51235 B	Lower Looper Bar Driving Lever Shaft -----	1
35	39508 B	Lower Looper-----	1
36	39151	Nut - Lower Looper Bar -----	1
37	39544	Lower Looper Bar -----	1
38	77	Screws - Connection Link Pin -----	2
39	39544 D	Lower Looper Bar Connection Link Pins -----	2
40	39544 B	Lower Looper Bar Connection Link -----	1
41	29126 DF	Lower Looper Bar Driving Lever and Connecting Rod Assembly -----	1
42	22729 D	Screw, for No. 39544 N -----	2
42 A	22729 E	Screw, for No. 39544 N -----	2
43	97	Screw, for No. 39544 S -----	2
44	39544 S	Ball Joint Guide Fork -----	1
45	39544 U	Lower Looper Bar Driving Lever -----	1
46	39594 N	Oil Splasher -----	1
47	77	Screw -----	1
48	22539 K	Plug Screw - Lower Looper Shaft -----	1

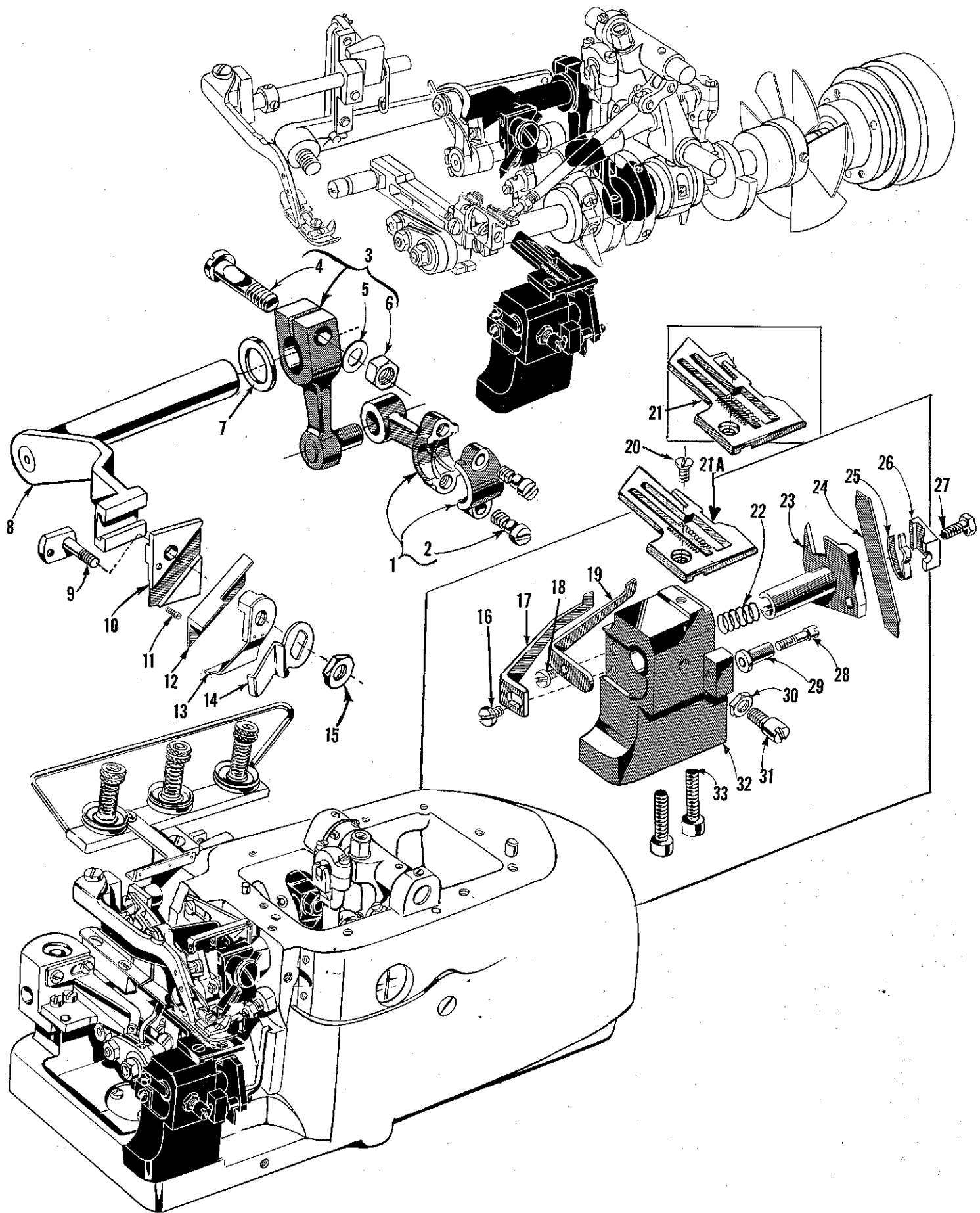

UPPER AND LOWER KNIFE MECHANISM

<u>Ref. No.</u>	<u>Part No.</u>	<u>Description</u>	<u>Amt. Req.</u>
1	39573 J	Upper Knife Driving Connecting Rod-----	1
2	22587 J	Screws - Connecting Rod-----	2
3	39573 E	Upper Knife Driving Lever-----	1
4	55235 D	Locking Stud - Driving Lever-----	1
5	6042 A	Washer - Driving Lever-----	1
6	55235 E	Nut - Driving Lever-----	1
7	39573 A	Upper Knife Driving Arm Washer-----	1
8	39573 H	Upper Knife Driving Arm-----	1
9	39571 D	Upper Knife Clamp Stud-----	1
10	39572	Upper Knife Holder Block-----	1
11	22738	Screw - Holder Block-----	1
12	39570	Upper Knife-----	1
13	39571	Upper Knife Clamp-----	1
14	39571 B	Upper Knife Chain Guard-----	1
15	14077	Nut - Upper Knife Assembly-----	1
16	22585 A	Screw - Needle Guard, front-----	1
17	39525	Needle Guard, front-----	1
18	22585 A	Screw - Needle Guard, rear-----	1
19	39525 A	Needle Guard, rear-----	1
20	22524	Screw - Throat Plate-----	1
21	39524 C-3/32	Throat Plate, marked "AC-3/32", 3/32 inch wide seam, for Style 39500 A-----	1
	39524 C-1/8	Throat Plate, marked "AC-1/8", 1/8 inch wide seam, for Style 39500 A-----	1
21A	39524 B-3/32	Throat Plate, marked "V-3/32", 3/32 inch wide seam, for Style 39500 B, AF-----	1
	39524 B-1/8	Throat Plate, marked "V-1/8", 1/8 inch wide seam, for Style 39500 B, AF-----	1
	39524 P	Throat Plate, marked "AJ", 1/8 inch wide seam, for Style 39500 P-----	1
	39524 B-5/32	Throat Plate, marked "BH", 5/32 inch wide seam, for Style 39500 AF-----	1
22	39550 E	Lower Knife Holder Spring-----	1
23	39550 B	Lower Knife Holder-----	1
24	39549	Lower Knife-----	1
25	39550 M	Lower Knife Clamp Spring-----	1
26	39550 L	Lower Knife Clamp-----	1
27	22588 A	Screw - Lower Knife Holder-----	1
28	22729 B	Screw - Lower Knife Holder Locking Stud-----	1
29	39550 C	Lower Knife Holder Locking Stud-----	1
30	14077	Nut - Locking Screw - Lower Knife Holder-----	1
31	22892 B	Locking Screw - Lower Knife Holder-----	1
32	39580 A	Throat Plate and Lower Knife Support Bracket-----	1
33	22653 B-12	Screws - Support Bracket-----	2

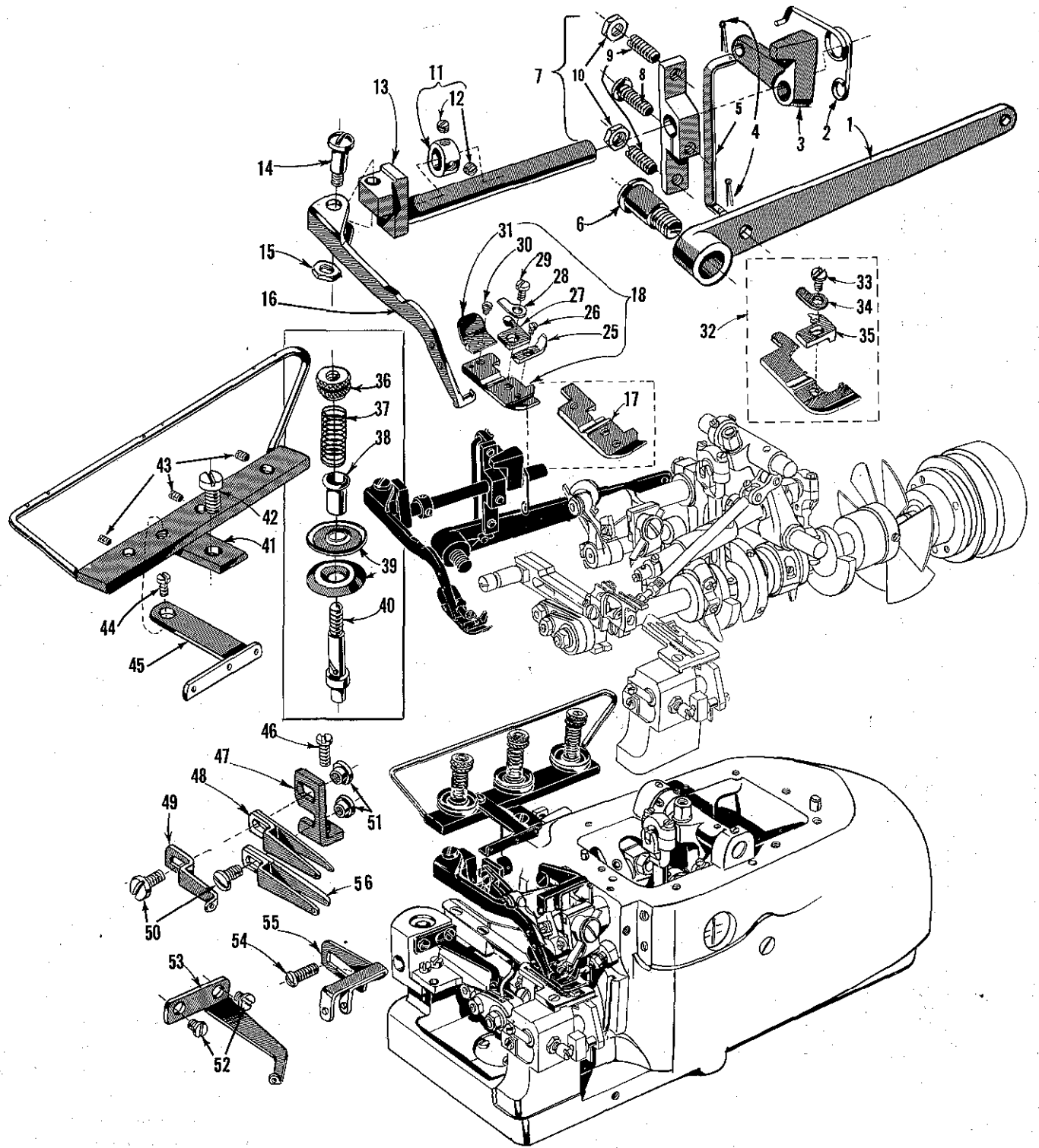

FOOT LIFTER, THREAD TENSIONS AND MISCELLANEOUS EYELETS

<u>Ref.</u> <u>No.</u>	<u>Part</u> <u>No.</u>	<u>Description</u>	<u>Amt.</u> <u>Req.</u>
1	39555	Foot Lifter Lever -----	1
2	39555 B	Foot Lifter Lever Spring -----	1
3	39555 D	Foot Lifter Intermediate Lever -----	1
4	660-142	Cotter Pins - Connecting Link -----	2
5	39555 F	Foot Lifter Lever Connecting Link -----	1
6	22566 B	Screw - Foot Lifter Lever -----	1
7	39555 C	Foot Lifter Lever Arm -----	1
8	627	Screw - Lever Arm -----	1
9	22597 E	Screws - Lever Arm -----	2
10	12538	Lock Nuts - Lever Arm -----	2
11	12865	Foot Lifter Lever Shaft Collar -----	1
12	88	Screws - Collar -----	2
13	39555 A	Foot Lifter Lever Shaft -----	1
14	22598 E	Screw - Presser Arm -----	1
15	14077	Nut - Presser Arm -----	1
16	39556 F	Presser Arm -----	1
17	39520 B	Presser Foot, for Style 39500 A -----	1
18	39520 A	Presser Foot, for Style 39500 B, AF -----	1
25	39530 P	Presser Foot Chip Guard -----	1
26	22738 B	Screw - Chip Guard -----	1
27	39597 A	Presser Foot Stitch Tongue, marked "DS" -----	1
28	39530	Presser Foot Hinge Spring -----	1
29	22768 B	Screw - Tongue and Spring -----	1
30	22738 B	Screw - Chain Shield -----	1
31	39530 C	Presser Foot Chain Shield -----	1
32	39520 P	Presser Foot, for Style 39500 P -----	1
33	22768 B	Screw - Stitch Tongue -----	1
34	39530	Hinge Spring -----	1
35	39597 P	Stitch Tongue, marked "EA" -----	1
36	108	Tension Post Nuts -----	3
37	51292 F-4	Looper Thread Tension Springs -----	2
	51292 F-8	Needle Thread Tension Spring -----	1
38	107	Tension Post Ferrules -----	3
39	109	Tension Discs -----	6
40	35792 H	Tension Posts -----	3
41	39592 F	Tension Post Mounting Bracket -----	1
42	22891	Screw - Tension Post Mounting Bracket -----	1
43	22565 C	Screws - Tension Posts -----	3
44	90	Screw - Thread Guide -----	1
45	39563 S	Thread Guide -----	1
46	22569 B	Screw - Eyelet Mounting Bracket -----	1
47	39568 D	Looper Thread Eyelet Mounting Bracket -----	1
48	39568 L	Upper Looper Thread Eyelet -----	1
49	39568 E	Auxiliary Looper Thread Eyelet -----	1
50	376 A	Screws - Looper Thread Eyelets -----	2
51	43139 A	Nuts - Looper Thread Eyelets -----	2
52	73 X	Screws - Frame Thread Guide -----	2
53	39568 W	Frame Thread Guide - Lower Looper Thread -----	1
54	22569 D	Screw - Needle Thread Eyelet -----	1
55	39563 H	Needle Thread Eyelet -----	1
56	39568 B	Lower Looper Thread Eyelet -----	1

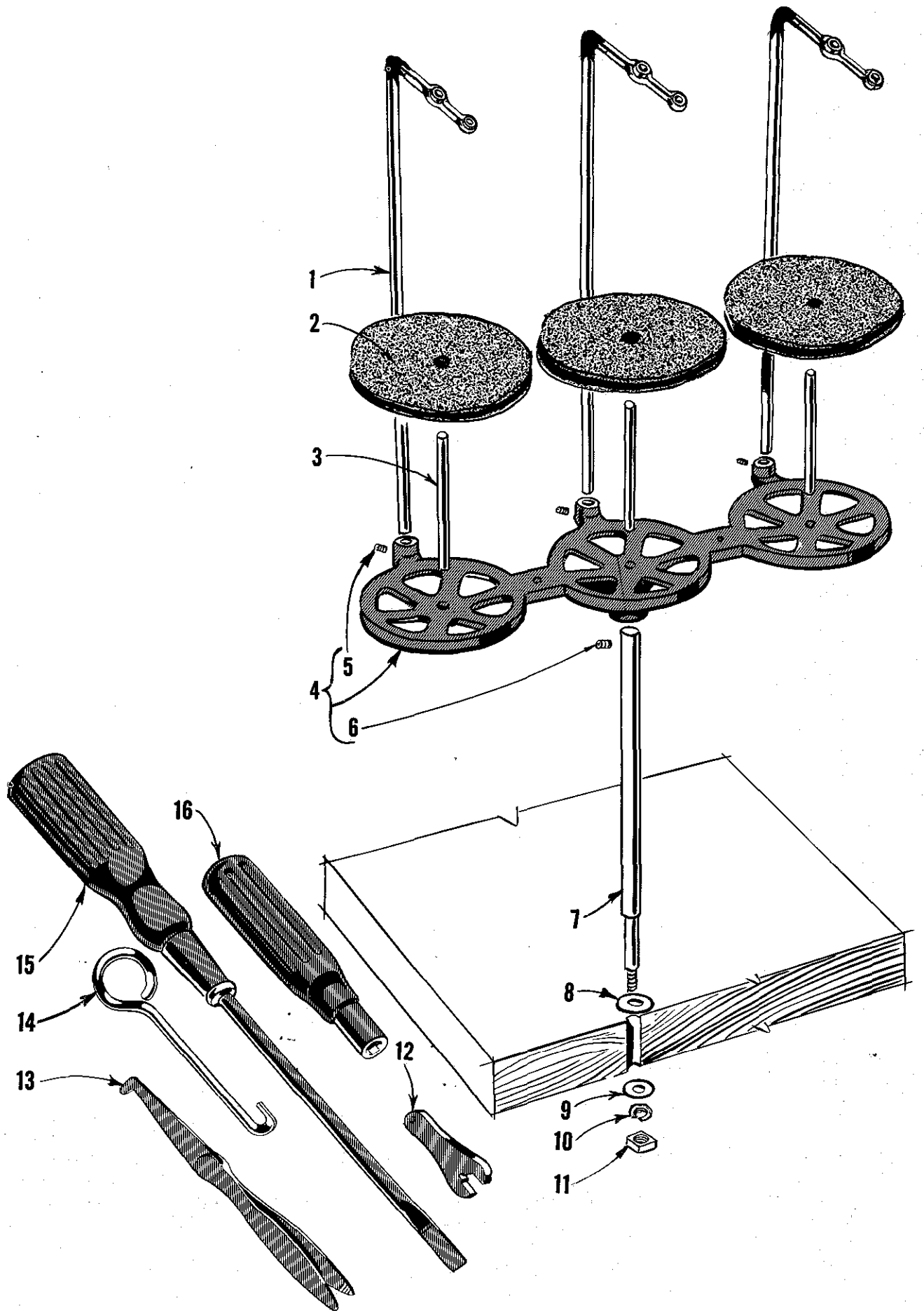

THREAD STAND AND MISCELLANEOUS TOOLS

Ref. No.	Part No.	Description	Amt. Req.
1	21113 F	Thread Eyelet and Support Rod -----	3
2	21104 V	Felt Pad -----	3
3	69 S	Spool Pin-----	3
4	21130 W-3	Cone Support -----	1
5	22650 CB-4	Screws - Cone Support-----	3
6	22650 CE-6	Screw - Cone Support-----	1
7	21104 AA	Thread Stand Rod -----	1
8	652 J-24	Washer - Thread Stand Rod -----	1
9	652 J-16	Washer - Thread Stand Rod -----	1
10	WA9 A	Lock Washer -----	1
11	651 A-16	Nut - Thread Stand Rod -----	1
12	116	Wrench, for 9/32 inch nuts-----	1
13	660-240	Thread Tweezers -----	1
14	21227 BF	Feed Eccentric Extractor Hook -----	1
*15	21202	Screw Driver, 1/4 inch diameter, 11 inches long -----	1
16	21388 AU	Socket Wrench, for 3/8 inch nuts holding feed eccentrics -----	1
* ----- May Be Purchased As An Extra Send And Charge Item.			

ACCESSORIES AVAILABLE AS EXTRAS (Not Illustrated)

21233 GG	Light Fixture Assembly, including blue lens, machine mounting for machines driven by "Electro Drive" which supplies the current.
21261 M-360	No. 1 "V" Belt, 36 inches long, for fully submerged individual power table installations.
21261 M-380	No. 1 "V" Belt, 38 inches long, for semisubmerged individual power table installations.
21261 M-400	No. 1 "V" Belt, 40 inches long, for nonsubmerged individual power table installations.
21377 BA	Tray, 1 3/4 inches high, for semisubmerged installations.
21377 BF	Tray, 1 3/4 inches high, for semisubmerged installations with front section extended to right.
21695 U	Finger Protector
39556 B	Presser Arm Chain Cutting Knife, lower.
39556 C	Presser Arm Chain Cutting Knife, upper.
605	Presser Arm Chain Cutting Knife Screws (two needed).
39595	Isolator, rubber.
39598	Knife Grinder, complete.
52978 J	Chip Disposal Chute.

		Belt Slot to Right Edge of Board	Cloth Plate to Front Edge of Board
21371 UH	Individual Power Table		
21371 PJ-48	Table Top, 48 x 20 x 1 3/4 inches, for individual power table installations: Nonsubmerged - no chip chute;	14 inch	3/8 inch
21371 RD-48	Table Top, same except Nonsubmerged;	7 1/2 inch	3 inch
21371 RF-48	Table Top, same except Nonsubmerged - no chip chute;	7 1/2 inch	3/8 inch
21371 RJ-48	Table Top, same except Semisubmerged;	10 1/2 inch	2 1/4 inch
21371 RL-48	Table Top, same except Semisubmerged;	7 1/2 inch	2 1/4 inch
21371 RG-48	Table Top, same except Fully Submerged	7 1/2 inch	2 1/4 inch
21371 RK-48	Table Top, same except Fully Submerged	10 1/2 inch	2 1/4 inch
21371 RC-47 3/4	Table Top, 47 3/4 x 16 x 1 3/4 inches, for line shaft installations: Nonsubmerged - no chip chute	7 1/2 inch	3/8 inch
21371 RE-47 3/4	Table Top, same except Nonsubmerged	7 1/2 inch	3 inch
21371 RH-47 3/4	Table Top, same except Semisubmerged	7 1/2 inch	2 1/4 inch

NUMERICAL INDEX OF PARTS

Part No.	Page No.	Part No.	Page No.	Part No.	Page No.	Part No.	Page No.
WA9 A	29	22569 B	17, 21, 27	39526 P	21	39563 S	27
18	21	22569 C	17	39530	27	39568 A	21
20	21	22569 D	17, 27	39530 C	27	39568 B	27
22 KH	23	22569 G	21	39530 P	27	39568 D	27
28	21	22571 E	17	39532 A	17	39568 E	27
50-774 Blk	21	22585 A	25	39534	21	39568 G	17
51-103 Blk	17	22586 R	17	39534 G	21	39568 J	17
69 S	29	22587 J	21, 25	39534 H	21	39568 L	27
73 X	27	22588 A	25	39534 R	17	39568 W	27
77	21, 23	22596 E	21	39535	21	39568 Y	21
77 Q	19	22597 E	27	39535 B	21	39570	25
86 X	17	22598 E	27	39535 C	21	39571	25
87	21	22650 CB-4	29	39535 D	21	39571 B	25
88	27	22650 CE-6	29	39536 A	21	39571 D	25
88 B	21	22653 B-12	25	39536 B	21	39572	25
90	17, 27	22653 D-4	17	39536 C	21	39573 A	25
93 A	21	22657 D-12	17	39536 E	21	39573 E	25
95	19	22729 B	25	39536 Z	21	39573 H	25
97	23	22729 D	23	39538	21	39573 J	25
97 A	19	22729 E	23	39540 B-10	21	39573 K	19
107	27	22738	25	39540 B-12	21	39573 L	19
108	27	22738 B	27	39541	19	39578 B	17
109	27	22743	17	39543	23	39578 F	17
116	29	22747	23	39543 A	23	39578 P	21
138	17	22747 B	19	39543 E	23	39578 R	21
376 A	27	22768 B	27	39543 H	23	39580 A	25
482 C	23	22769 A	19	39543 K	23	39582 AA	17
627	27	22797 A	21	39543 M	23	39582 D	17
651 A-16	29	22891	27	39543 P	23	39582 F	17
652 J-16	29	22892 B	25	39543 R	23	39582 L	17
652 J-24	29	22894 C	23	39543 S	23	39582 S	17
660-142	27	22894 D	19	39543 T	23	39582 V	17
660-207	21	22894 AD	17, 23	39544	23	39582 X	17
660-234	17	29126 CG	23	39544 B	23	39582 Y	17
660-240	29	29126 DF	23	39544 D	23	39590	19
660-243	17	29477 GW	17	39544 L	19	39590 D	19
660-268	19	35792 H	27	39544 S	23	39590 G	19
* 666-94	19	39142 G	19	39544 U	23	39590 H	19
1280	23	39151	23	39549	25	39590 J	19
6042 A	25	39501	17	39550 B	25	39590 K	19
7446 A	23	39501 A	17	39550 C	25	39590 N	19
8372 A	21	39501 B	17	39550 E	25	39590 P	19
12538	27	39501 C	17	39550 L	25	39590 R	19
12865	27	39501 K	17	39550 M	25	39590 S	19
14077	21, 25, 27	39505	21	39551 A	21	39590 T	19
21104 V	29	39505 B	21	39551 F	21	39591	19
21104 AA	29	39505 C	21	39552	21	39591 A	19
21113 F	29	39505 D	21	39552 A	21	39591 B	19
		39505 E	21	39552 C	21	39591 G	19
21130 W-3	29	39505 P	21	39552 E	21	39591 H	19
21202	29	39508 A	23	39552 N	19	39592 F	27
21227 BF	29	39508 B	23	39555	27	39593 C	17
21388 AU	29	39520 A	27	39555 A	27	39593 D	17
22503 F	23	39520 B	27	39555 B	27	39593 E	17
22524	25	39520 P	27	39555 C	27	39594	17
22528	21	39521	19	39555 D	27	39594 G	17
22539 K	23	39521 A	19	39555 E	19	39594 H	17
22541	17	39522 B	19	39555 F	27	39594 N	21, 23
22559 A	23	39522 C	19	39556 A	17	39597 A	27
22562 A	23	39524 B-3/32	25	39556 F	27	39597 P	27
22564	21	39524 B-1/8	25	39557	17	41071 G	17
22564 G	23	39524 B-5/32	25	39557 A	17	41255 B	23
22565	17, 23	39524 C-3/32	25	39557 B	17	43139 A	27
22565 C	27	39524 C-1/8	25	39557 C	17	43143 N	23
22565 F	19, 21	39524 P	25	39557 E	17	51235 B	23
22565 H	23	39525	25	39557 F	17	51292 F-4	27
22566 B	27	39525 A	25	39563 F	17	51292 F-8	27
22569	17, 19, 21	39526 B	21	39563 G	21	53634 C	21
22569 A	17	39526 D	21	39563 H	27	55235 D	25
* 666-255	23					55235 E	25



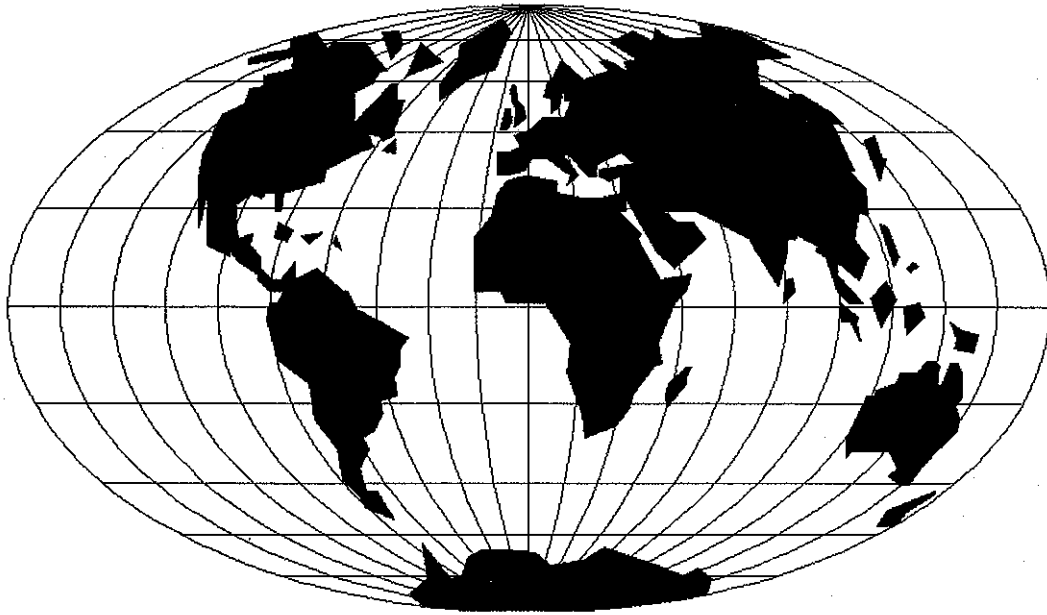

WORLDWIDE SALES AND SERVICE

Union Special Corporation maintains sales and service facilities throughout the world. These offices will aid you in the selection of the right sewing equipment for your particular operation. Union Special Corporation representatives and service technicians are factory trained and are able to serve your needs promptly and efficiently. Whatever your location, there is a qualified representative to serve you.

Corporate Office: One Union Special Plaza
Huntley, IL 60142
Phone: 847•669•5101
Fax: 847•669•1096

European Distribution Center: Union Special GmbH
Raiffeisenstrasse 3
D-71696 Möglingen, Germany
Tel: 49•07141•247•0
Fax: 49•7141•247•100

Brussels, Belgium
Charlotte, N.C.
El Paso, TX
Hong Kong, China
Huntley, IL
Leicester, England
Lille, France
Miami, FL
Milan, Italy
Möglingen, Germany
Montreal, Quebec
Osaka, Japan
Santa Fe Springs, CA

Other Representatives throughout
all parts of the world.



Union Special
INDUSTRIAL SEWING EQUIPMENT